

## IRD series 8" LED Inset Lights

### COMPLIANCE

- ICAO • Annex 14 Volume I
- EASA • CS-ADR-DSN
- IEC • TS 61827
- FAA • AC 150/5345-46  
• EB No. 67
- NATO • STANAG 3316
- AENA • DIN/DSEYN/PPT/010  
• DIN/DSEYN/PPT/012  
• DIN/DSEYN/PPT/013
- Canada • TP 312
- Australia • MOS 139
- CAAC • AC-137-CA-2015-01-R1  
• AC-137-CA-2015-03-R1

### FEATURES

- Low protrusion of 6 mm above ground level
- Adaptable to all kinds of CCRs and ILCMS systems
- PWM digital regulation providing excellent consistency of chromaticity
- Integrated optical module with high light efficacy and good consistency
- Aluminum alloy forged top cover with hardened surface and corrosion resistance treatment
- Built-in surge protection
- Specially designed fail open system suitable for strong magnetism, vibration and other environments

- RC/IN Runway Centre Line
- TZ/IN Touchdown Zone
- FI/IN Rapid Exit Taxiway Indicator
- RE/IN Runway End  
Take-off and Hold  
Stopway

### TECHNICAL DATA

#### MECHANICAL

Mounting • 2 x M10 bolts      Static Load Resistance •  $\geq 20t$       Dynamic Load Resistance • 40J      Net Weight • 3.5kg  
 Gross Weight • 3.7kg      Packing Dimensions • 253mm (L) x 223mm (W) x 107mm (H)

#### ENVIRONMENTAL

Operating Temperature • - 55°C~+55°C      Storage Temperature • - 55°C~+85°C      Protection Class • IP68      Humidity • 0~100%

#### ELECTRICAL

Connection • FAA L-823      Rated Input Current • 6.6A/2.2A      Power Factor • >0.98  
 Emission • IEC 61000-6-4      Immunity • IEC 61000-6-2      LED Lamp Life • Over 100,000 hours in typical operating conditions  
 Runway Centre Line -White/White • 20VA (1P) • 11/11VA (2P)      Runway Centre Line -White/Red • 17VA (1P) • 11/8VA (2P)  
 Runway Centre Line -White • 14VA      Runway Centre Line -Red • 11VA      Touchdown Zone • 14VA  
 Runway End • 13VA      Take-off and Hold • 13VA      Rapid Exit Taxiway Indicator • 15VA

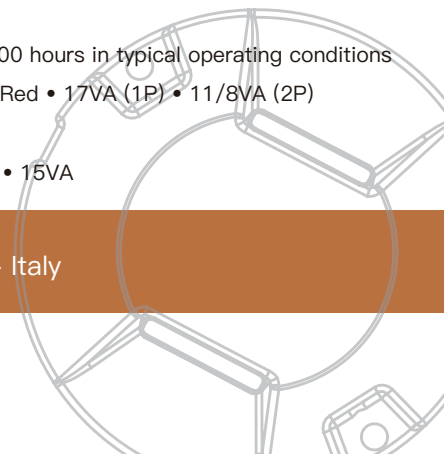

## COMPONENTS

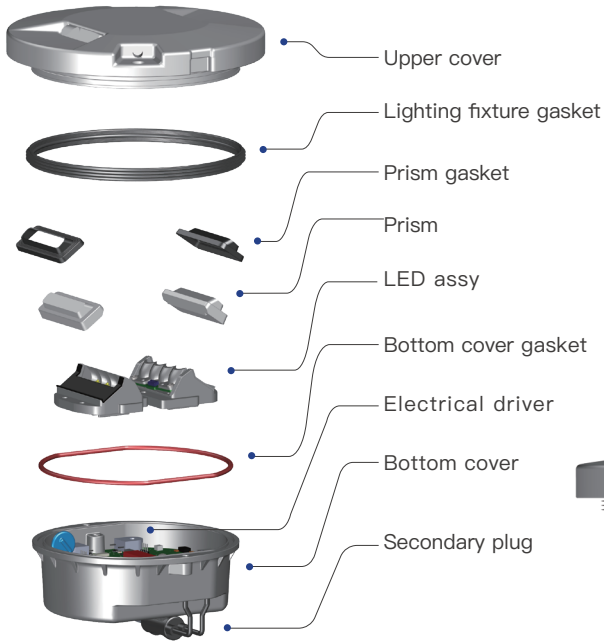

## DIMENSIONS

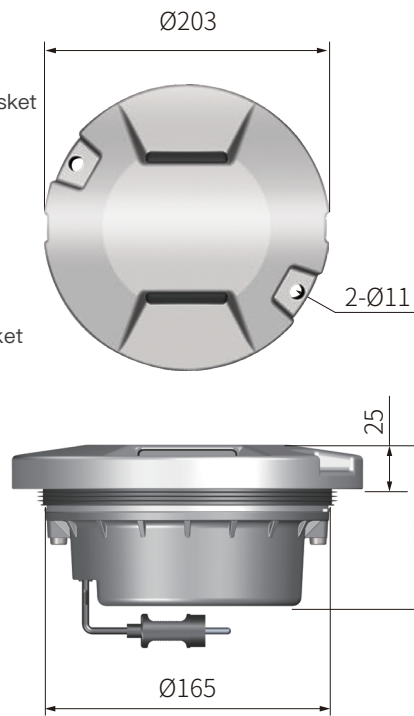

## ACCESSORIES

- ⊙ 8 inches shallow base assy (bottom entry/side entry)
- ⊙ 12 inches shallow base assy (bottom entry/side entry)
- ⊙ 12 inches deep base assy
- ⊙ 8-12 inches adapter ring assy
- ⊙ L-823 receptacle
- ⊙ 8 inches light fixture handle

## PHOTOMETRICS

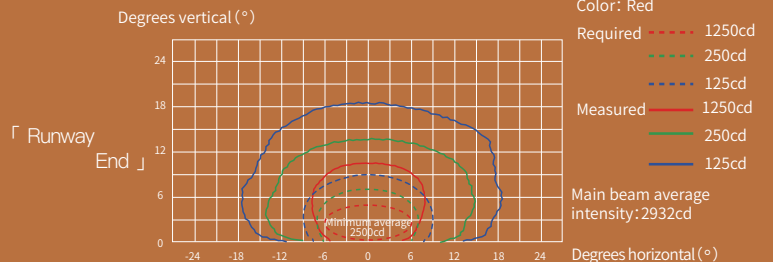
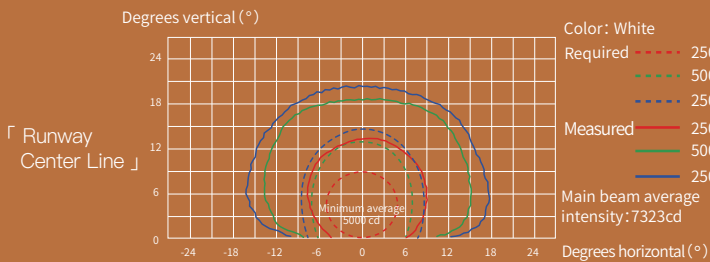

## ORDERING CODES

